

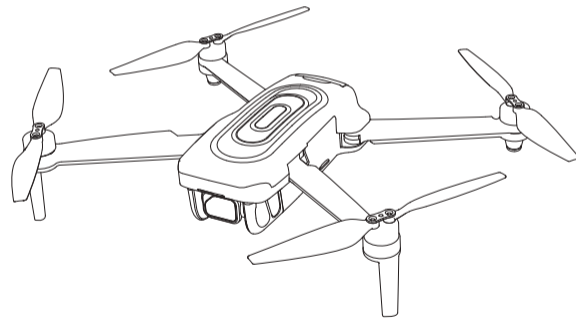

HS175G

User Manual
Gebrauchsanweisung

V1.1



+1(833)766-4733
www.holystone.com

usa@holystone.com (USA)
ca@holystone.com (CA)

eu@holystone.com (EU)
au@holystone.com (AU)

English

01-53

Deutsch

54-104

CONTENTS

1

Product Profile

- 01 Package Contents
- 02 Diagram of the Drone
- 03 Diagram of the Transmitter

3

Drone Functions

- 26 Flight Functions
- 36 Stabilization Functions
- 39 APP Functions
- 44 Drone Status Indicator

2

Operation Guide

- 07 Charging 15 Flight
- 09 Pre-Flight Preparations
- 14 Pre-Flight Checklist

4

Appendix

- 45 Specifications 49 Compliance Information
- 47 Contact Us
- 48 Troubleshooting

Reading Guidance

Icon

“⚠️” essential precautions. “💡” tips for operation and usage.

Recommended Steps

Our product offers both tutorial videos and the following resources:

- Disclaimer and Safety Guidelines
- Quick Start Guide
- User Manual

For a smooth start, we suggest watching the tutorial videos and reviewing the "Disclaimer and Safety Guidelines" first. Then, familiarize yourself with the basics through the "Quick Start Guide". For a comprehensive understanding, delve into the "User Manual".

Access tutorial Videos

To ensure you're using the product safely and correctly, scan the QR code below to view our tutorial videos.



Download the HS GPS V5 App

Simply scan the QR code below.



iOS



Android APP on Google play

1.1 Package Contents >>

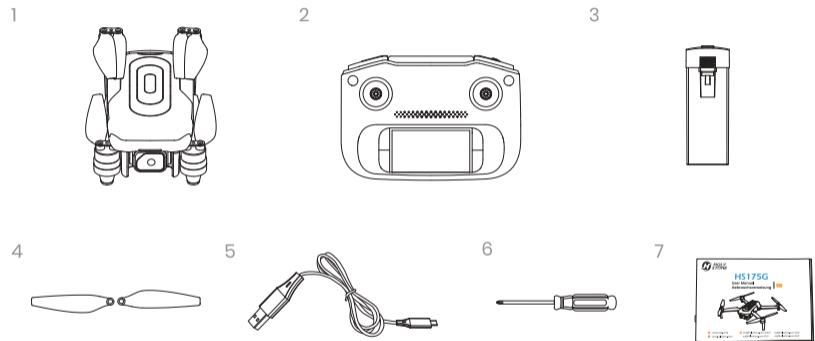

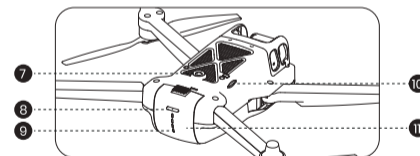
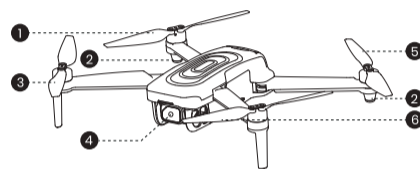

- 1 Drone 2 Transmitter 3 Drone Battery 4 Propellers
- 5 USB Charging Cable 6 Screwdriver 7 User Manual

1.2 Diagram of the Drone >>



- 1 Propeller A
2 Status Lights
3 Propeller B
4 Camera
5 Propeller B
6 Propeller A
7 Optical Flow Positioning Lens
8 Power Switch
9 Battery Level Lights
10 TF Card Slot
11 Drone Battery

- 💡 · Turning on/off: Press and hold the power switch () for 3 seconds.
- Checking battery level: Short press the power switch () once to turn on the drone battery lights (display the current battery level of the drone).

1.3 Diagram of the Transmitter >>

The Transmitter

● Front:

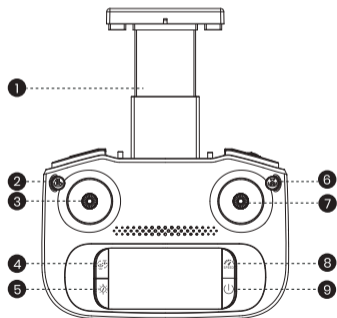

● Top:

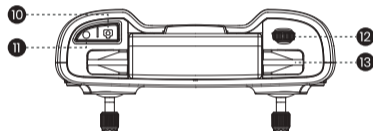

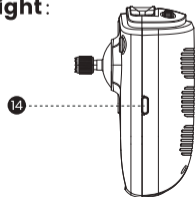

● Right:



- | | |
|-----------------------------------|--|
| 1 Phone Holder | 2 Takeoff/Landing: short press |
| 3 Left Joystick | 4 GPS Switch: short press
Headless Mode: long press |
| 5 Compass Calibration: long press | 6 Return to Home (RTH): short press |
| 7 Right Joystick | 8 Speed Switch: short press |
| 9 Power Switch: long press | 10 Take Photo: short press |
| 11 Record Video: short press | 12 Camera Dial |
| 13 Cellphone Slot | 14 Charging port (Type-C) |



- Turning on/off: Press and hold the power switch () for 3 seconds.
- Press the Power switch () once to check the current battery level. If the battery level is too low, recharge before use.

1.3 Diagram of the Transmitter >>

Joystick Mode

- **MODE 2 :** (The default setting.)

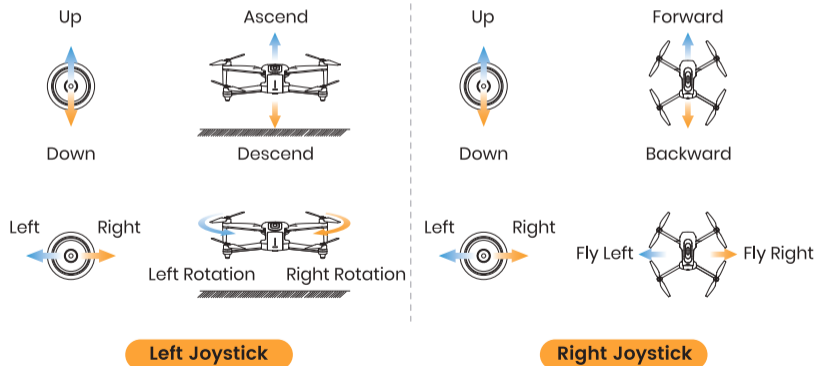

- **MODE 1 :** To enter MODE 1, turn on the transmitter while holding the  button. (Please do not release the  button until the transmitter is powered on.)

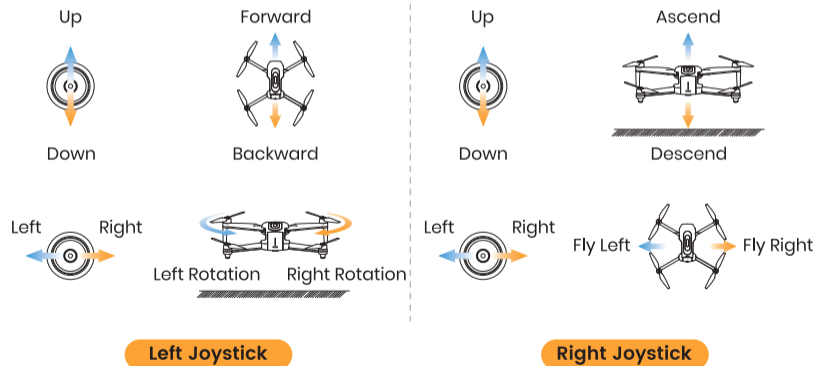

1.3 Diagram of the Transmitter >>

LCD Screen

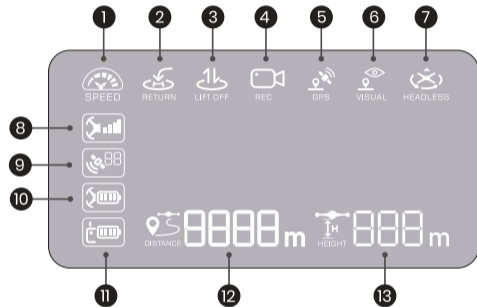

- | | | |
|--------------------------|-------------------------------|--------------------------------------|
| 1 Flight Speed | 2 RTH Indicator | 3 Takeoff/Landing Indicator |
| 4 Photo/Record Indicator | 5 GPS mode Indicator | 6 Optical Flow Positioning Indicator |
| 7 Headless Mode | 8 Transmitter Signal Strength | 9 GPS Signal Strength |
| 10 Drone Battery Level | 11 Transmitter Battery Level | 12 Flight Distance |
| 13 Flight Height | | |

2.1 Charging >>

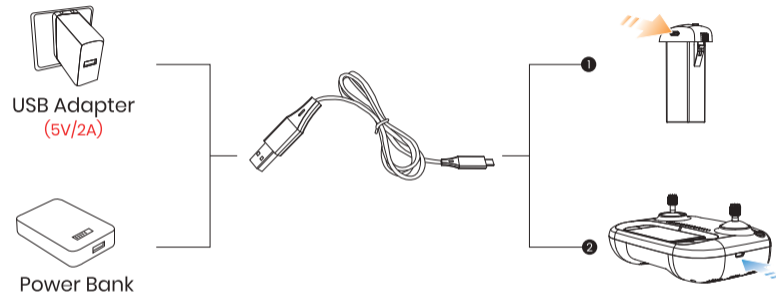

- ⚠ Before charging, please read the instructions in the "Battery Safety" section of the "Disclaimer and Safety Guidelines" carefully!
- DO NOT charge a battery immediately after a flight as the temperature may be too high. Please wait until it cools down to room temperature before charging again.
- Please use the original charging cable to charge the battery.

2.1 Charging >>

• Charging of the Drone Battery:

- 1 Remove the battery from the drone and connect it to a USB charging cable.
- 2 Plug the USB charging cable into a USB charging port on a power bank or a USB adapter (5V/2A).
- 3 When charging, the battery lights of the drone flash blue; When fully charged, all battery lights turn solid on.
- 4 Fastest charging time: approximately 1.5 hours (using Fast Chargers).
- 5 It is recommended to use USB chargers that support PD3.0 or QC5.0 fast charging protocols.

• Charging of the Transmitter:

* **Low Battery Signal:** The light on the transmitter keeps flashing, and the transmitter keeps beeping.

- 1 Connect the USB charging cable to the charging port of the transmitter.
- 2 Plug the USB charging cable into a USB charging port on power bank or USB adapter (5V/2A).
- 3 When charging, the LCD screen displays the current battery level. When the charging is done, the LCD screen shows "100%."
- 4 Charging time: about 4 hours.

2.2 Pre-Flight Preparations >>

Arms

All arms of the drone are folded before the drone is packaged at the factory. First, unfold the front arms, then unfold the rear arms.

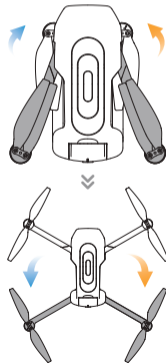

TF Card

To store your photos and videos, insert a TF card (**not included**) into the slot before turning on the drone. This drone supports TF cards (**class 10 or above**) with capacities up to and including 128GB.

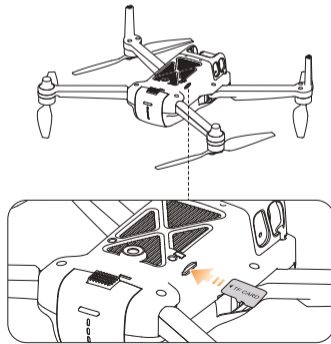

2.2 Pre-Flight Preparations >>

Propellers

● Installation:

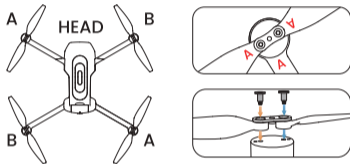

The drone will not fly unless the correct propeller is installed on the correct motor shaft. Each propeller is labeled with either an "A" or "B" on it. Secure the propeller onto the motor shaft using screws, turning each screw clockwise.

● Removal:

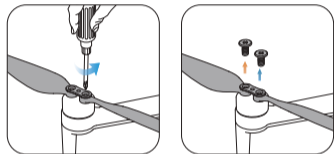

For propeller removal, use a screwdriver (provided) to rotate the screws counter-clockwise and remove the propellers. Be sure to hold the motor while detaching the propeller.

- ⚠ Please check that the propellers are properly installed and tightened before each flight.
- Exercise caution when attaching/detaching the propellers to prevent any cuts or injuries.
- The propellers are installed before the drone is packaged at the factory.

2.2 Pre-Flight Preparations >>

Drone Battery

● Installation:

*Before installing the battery, please check if it has a detachable insulation pad/band. If yes, remove it.

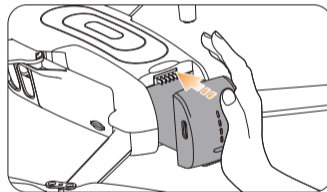

Push the battery correctly into the drone. Make sure that you hear a click sound, which indicates that the battery is firmly installed.

- ⚠ The battery should be installed firmly. Otherwise, the flight safety of your drone may be affected. The drone may crash due to a power-cut during the flight.

● Removal:

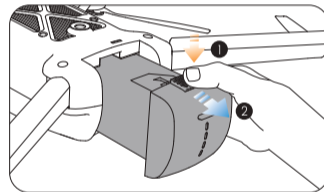

Turn the drone upside down. Press the lock button on the battery, and pull the battery out from the drone.

2.2 Pre-Flight Preparations >>

Phone Holder

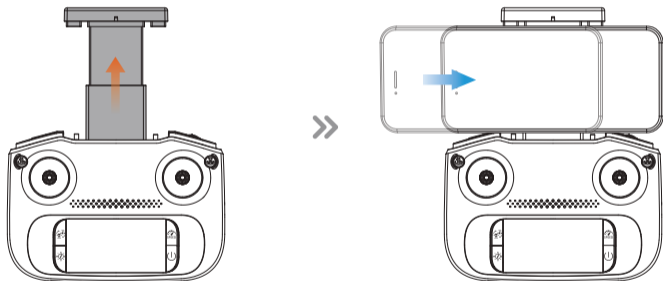

Expand the phone holder and place your mobile phone in it. Adjust the clamp to secure your mobile phone.

2.3 Pre-Flight Checklist >>

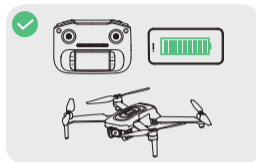

Make sure the transmitter, the mobile phone and the drone battery are fully charged.

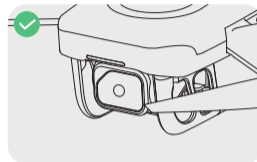

Make sure that the camera is clean.

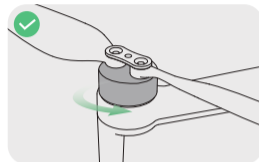

Make sure that there is nothing obstructing the motors.



Make sure the drone arms are unfolded.

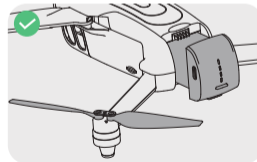

Make sure the drone battery and the propellers are mounted securely.



Please ensure that you use only accessories manufactured by our company.

2.4 Flight >>

Pairing

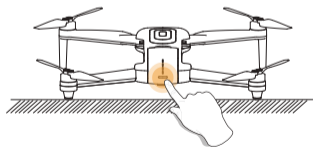

- All of the operations shown in this manual are demonstrated using MODE 2.
- Make sure that you go outdoor to an open area to operate the drone.

**1 Turning on the drone:**

Set the drone on a flat, level surface, positioning it so that the front faces away from you and the tail points towards you. Press and hold the power switch (⏻) for 3 seconds to turn it on. The status lights on the drone begin to flash red.

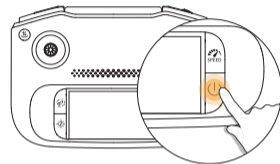
**2 Turning on the Transmitter:**

Press and hold the power switch (⏻) for 3 seconds to turn it on; the transmitter will beep once.

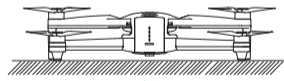
**3 Auto-Pairing:**

Once the transmitter and the drone have successfully paired, the  icon on the LCD screen will switch from flashing to a steady glow.

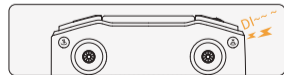

2.4 Flight >>

Wi-Fi Connection

 Make sure the pairing has finished before going to the Wi-Fi settings on your phone.

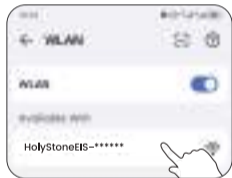

- 1 Go to the Wi-Fi settings on your phone.
- 2 Connect to the drone's Wi-Fi network: **HolyStoneEIS-*******.
- 3 Run the **HS GPS V5** app. A successful connection is confirmed when the drone's live video feed is displayed within the app interface.



- Connecting your phone to the drone's Wi-Fi may take some time. Please remain patient and wait for the connection to be established successfully.
- For optimal connectivity, if you're experiencing issues with the WIFI connection or the image transmission in the APP isn't displaying, it's advised to disable your phone's Bluetooth, Mobile Data, and VPN. Alternatively, switch your phone to airplane mode and attempt to reconnect.
- Please ensure that **all** permissions requested by the app are granted.



The Wi-Fi network created by the drone does not have internet access. As a result, your cellphone might:

- Notify you that the connection isn't secure,
- Indicate there's no internet connection, or
- Suggest switching to cellular data.

(The exact wording may vary based on cellphone models.)

Please disregard these messages. If prompted, select the option to remain connected to the current Wi-Fi.

2.4 Flight >>

Compass Calibration

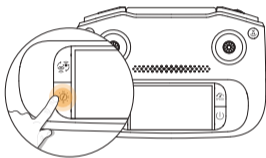

- **STEP 1:**

Long press the  button to enter the compass calibration. The transmitter produces a short beep, indicating that the calibration has started. You can now proceed to step 2.

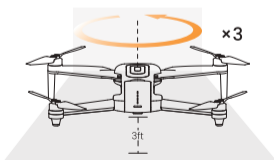

- **STEP 2:**

Keep the drone parallel to the floor, and spin the drone three times. The transmitter produces a short beep. You can proceed to step 3.

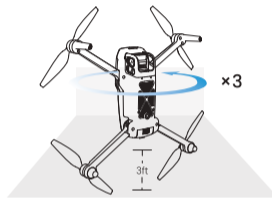

- **STEP 3:**

Point the head of the drone upward, and spin the drone three times. The transmitter produces a short beep, which means that you have successfully performed a compass calibration.



- To ensure a stable flight, we recommend that pilots perform a compass calibration before each flight.
- We recommend that the pilot hold the drone approximately 3 ft above the ground while performing the compass calibration.
- DO NOT calibrate the compass in locations where magnetic interference may occur, such as close to magnetite deposits or large metallic structures such as parking structures, steel reinforced basements, bridges, cars, or scaffolding.
- DO NOT carry objects (such as mobile phones) that contain ferromagnetic materials near the drone during calibration.

2.4 Flight >>

GPS Signal Search

Please don't use the GPS mode when you are indoors.

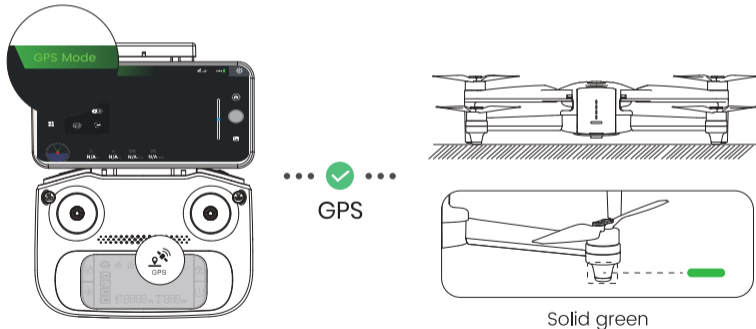

After calibrating the compass, put the drone on a flat surface. Make sure there are no external sources of signal interference around.

The drone will automatically perform a search for GPS signals. A successful search is confirmed when the drone status indicators turn solid green.



- The default mode is the GPS Mode. When outdoors, once the drone has received GPS signals, it CANNOT exit GPS mode.
- If the GPS signal is weak or if you plan to fly the drone indoors, you may notice that the drone status indicator emitting double yellow flashes. If you want it to take off, you can short press the  on the transmitter to exit the GPS mode. The LCD screen displays "RTTI MODE". The drone is ready for unlocking and takeoff when the drone indicator turns solid yellow. However, please note that all GPS-related functions will be unavailable now. The drone the maximum flying altitude does not exceed 20ft.
- If the drone takes off in non-GPS mode and the indicator starts to flash green mid-air, this means that the drone has regained GPS signals. Now, if you land the drone and then take off again, it will automatically switch back to GPS mode.

2.4 Flight >>

Gyro-Calibration

Make sure to place the drone on a level surface before calibrating the gyro. Simultaneously push the left joystick and the right joystick to the bottom right corner to calibrate the gyro. The indicator lights on the drone will blink, then turn solid, which indicates that the calibration is completed.



 To ensure a stable flight, we suggest that the pilot calibrates the gyro every time after pairing the drone and after a crash.

2.4 Flight >>

Unlocking the Motors

Short press the  button. The motors will rotate, and the drone is unlocked.

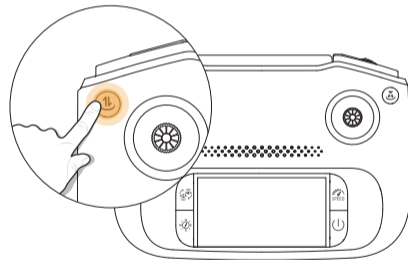



 To lock the motors: Pull the throttle joystick down to lock the motors.

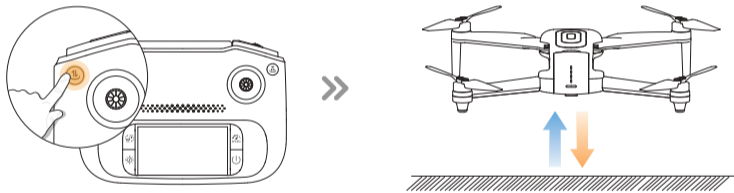

2.4 Flight >>

Takeoff/Landing

 Remember to unlock the motors before takeoff.



 **Takeoff** Short press the  button, the drone will take off automatically and hover at 5 ft. Now you can control the drone by using the joysticks.

 **Landing** During the flight, short press the  button, the drone will land on the ground automatically.

 When operating the drone, it's important to periodically adjust the orientation and distance between the transmitter and the drone to ensure that the drone always remains within the optimal communication range.

Optimal Reception Range:



Weaker Signal:

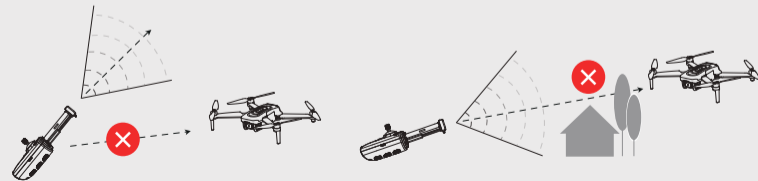

3.1 Flight Functions >>

Camera Angle Adjustment

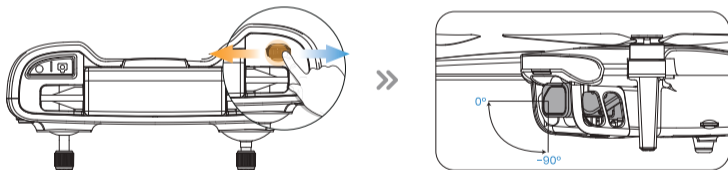

The control tilt range is -90° to 0° . Use the dial () to control the tilt of the camera.



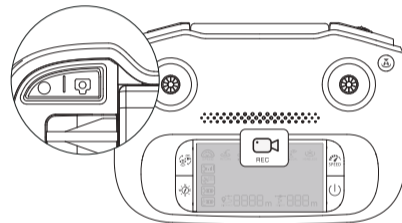

3.1 Flight Functions >>

Take Photo/Record Video



Take photo : Short press the  button on the transmitter to take a photo. The transmitter will beep once, and the Photo/Video Indicator  on the LCD screen will flash three times, signaling that a photo has been taken.

Record Video : Short press the  button on the transmitter. The transmitter will beep twice, and the Photo/Video Indicator  on the LCD screen will keep flashing, indicating that video recording has started. Short press the same button again to stop recording. The transmitter will beep twice.

3.1 Flight Functions >>



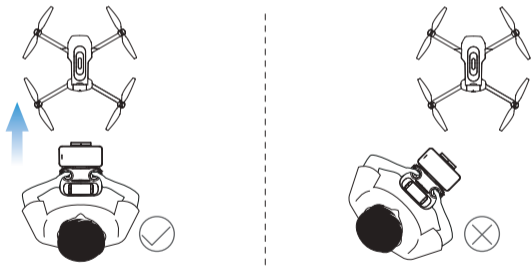

Headless Mode

The Headless Mode is a great training tool for beginner pilots. It is also useful when the drone is too far from the pilot **(which makes it difficult to tell its orientation)**. It keeps the drone traveling forward, backward, left, or right when you move the right joystick in those directions, regardless of which way the front of the drone is pointed.

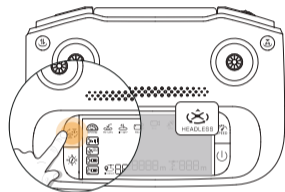

The pilot should stay facing the same direction that the drone's head points to when it takes off.



- 1 Activating:** Press and hold the  button. The transmitter will produce a prolonged beep, and the  icon on the LCD screen will stay on.
- 2 Deactivating:** Press and hold the  button. The transmitter will emit a short beep, and the  icon on the LCD screen will turn off. You have exited the headless mode.

* Why is the orientation of the drone important?

In normal flying mode, the control of the drone movement can sometimes be counter-intuitive for beginners. For instance, when the drone is in the air with its head pointing to your right, if you push the right joystick forward, the drone will fly to your right, instead of flying forward.

With the headless mode, the drone has a fixed "head." In Headless Mode, the drone always remembers the side its head points to during takeoff as the front side. This means that if the drone takes off with its head pointing forward, it doesn't matter how the drone is oriented in the air, when you push the right joystick forward, the drone will fly forward. Or, when its head is pointing to you, if you push the right joystick to the left, the drone will fly to your left.

3.1 Flight Functions >>

Speed Switch

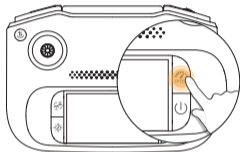

This drone offers two speed modes: Camera mode and Sport mode. Short press the  button once to switch speed. The Camera Mode speed is 7 m/s. The Sport Mode speed is 9 m/s.

- CAMERA MODE:**



The transmitter beeps once. The LCD screen displays "CAMERA MODE" ().

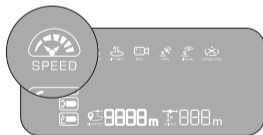

- SPORT MODE:**





The transmitter beeps twice. The LCD screen displays "SPORT MODE" ().

3.1 Flight Functions >>

Emergency Stop

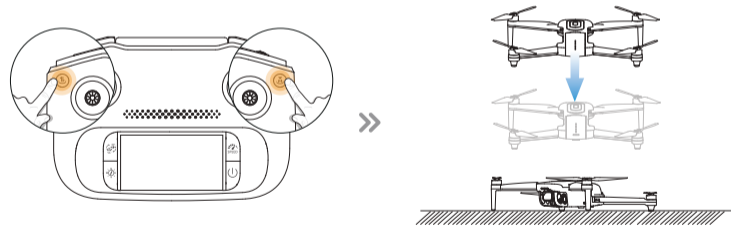
This Emergency Stop function should only be used in case of emergency to avoid damages or injuries. Keep in mind that the fall may damage the drone. Press and hold the  button and the  button for 3 seconds at the same time to initiate the emergency stop, and the drone will fall down immediately.





 Be aware that you risk breakage of the drone if it falls from a large distance or hits anything at a high rate of speed.

3.1 Flight Functions >>

Return to Home(RTH)

- The Return to Home function brings the drone back to the recorded Home Point. This function can only be triggered when the drone is in GPS mode.
- The drone's default home point is the location where it first receives a strong GPS signal (the drone status indicators are solid green at this point). The drone will record its takeoff position at that moment as the home point. During flight, if the drone lands at a new location, the position of the next takeoff will become the newly recorded home point.

- 1 Smart RTH :** When the GPS signal is strong (drone indicator status: solid green) and the Home point is recorded previously, press the  button, the transmitter keeps emitting beeping sounds, and the LCD screen displays "go home", indicating that the Smart RTH is activated. The drone will start flying back to the Home Point automatically.
During the RTH procedure, if the pilot presses the  button again, the drone will exit the RTH procedure immediately.

- 2 Failsafe RTH :**

The Failsafe RTH will be activated when:

1. The drone receives a strong GPS signal (drone indicator status: solid green); and
2. There is a pre-recorded Home Point; and

3. The connection between the transmitter and the drone is lost for more than 15 seconds.
4. The compass receives no interference.

Once the Failsafe RTH is activated, the app status bar shows "Remote Control Disconnected", and the drone will start to fly back to the pre-recorded Home Point automatically. If the connection between the drone and the transmitter is re-established during the Failsafe RTH procedure, and you want to exit the Failsafe RTH, you can press the  button again.

*** The following are 3 possible returning procedures for Smart RTH and Failsafe RTH:**

a When the Flight Distance is Greater than 66 ft:

- Flight Altitude Less than 164 ft: The drone will ascend to the user-set flight altitude before flying back to the Home Point.
- Flight Altitude 164 ft or Higher: The drone will fly back to the Home Point at the current altitude.

b When the Flight Distance is 66 ft or Less:

- Flight Altitude Less than 66 ft: The drone will ascend to an altitude of 66 ft before flying back to the Home Point.
- Flight Altitude 66 ft or Higher: The drone will fly back to the Home Point at the current altitude.

c When the Flight Distance is 6.6ft or Less:

- The drone will descend directly downward.

 The drone does not have an automatic obstacle avoidance feature. Be cautious to avoid collisions or other dangerous situations during the return flight to ensure a safe return.

3.1 Flight Functions >>

Return to Home (RTH)

③ Low Voltage RTH :

When the flight battery is too low or there is not enough power to return home, the user should land the drone as soon as possible to avoid damage to the drone or other hazards.

To prevent unnecessary risks due to insufficient battery power, the low voltage return-to-home (RTH) function will be automatically triggered when the drone battery is low. According to the remaining power, there are two scenarios:

The First Stage of Low Voltage RTH: The drone will automatically return to the Home Point. While the drone is returning, the  icon in the app will turn green and flash, and the transmitter will emit continuous beeping sounds.

After the drone returns, you will be restricted to flying it within a 'safety zone,' which is centered around the Home Point and has a radius of 66 ft. The drone will not be able to exit this zone.

The Second Stage of Low Voltage RTH: The drone will descend directly to the ground, the  icon in the app will turn red and flash, and the transmitter will emit rapid, continuous beeping sounds.

- ⚠ · During the RTH procedure, the drone can NOT avoid obstacles.
- If the GPS signal is weak or unavailable, the RTH cannot be activated.

3.2 Stabilization Functions >>

Altitude-Hold Function

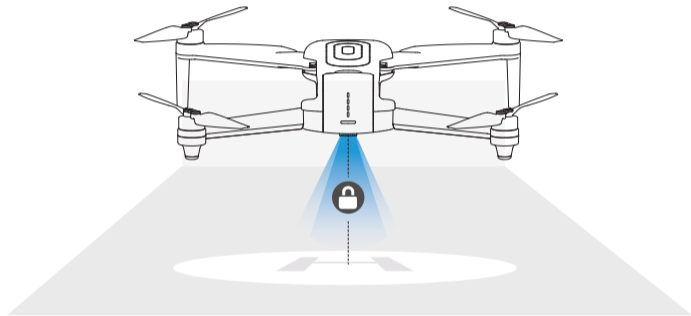

The drone is designed with an altitude-hold function to maintain its altitude after releasing the left joystick. (The left joystick will automatically spring back to the middle)

3.2 Stabilization Functions >>

Optical Flow Positioning

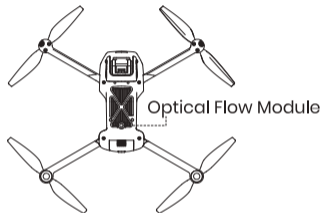

The Optical Flow Positioning System consists of a camera module, which acquires the position information of the drone through visual images to ensure precise positioning of the drone.

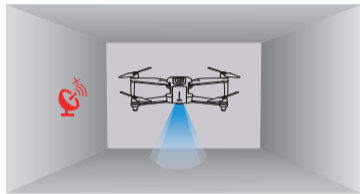

The Optical Flow Positioning System is typically used in an indoor environment when the GPS signal is weak or unavailable. The optimal usage height for Optical Flow Mode is **1.6-9.8 ft.**



- The precision of the Optical Flow Positioning System is easily affected by the light intensity and features of the surface textures. Once the image sensor is not available, your drone will switch on the altitude-hold function automatically. Please exercise utmost caution when operating the drone under these circumstances:

- Fly over surfaces without clear patterns or textures.
- Fly over extremely dark or bright surfaces.
- Fly in an area where the lighting changes dramatically and frequently.
- Fly over moving surfaces or objects. (e.g., above crowds, above bushes or grasses swayed by strong winds).
- Fly over water or transparent surfaces.
- Fly over highly light reflective surfaces. (e.g., mirrors).
- Fly over monochrome surfaces (e.g. pure black, red, or green).
- Flying over surfaces with repeating identical patterns or textures (e.g., tiles with the same design).
- Flying speed should be controlled not to be too fast.
- Keep sensors clean at all times.
- DO NOT scratch or tamper with the sensors. DO NOT use the aircraft in dusty or humid environments.
- Make sure that the light is bright enough and the surface is with clear textures so that the Optical Flow Positioning can acquire the movement information through recognizing the ground textures.

3.3 APP FUNCTIONS >>

App Interface

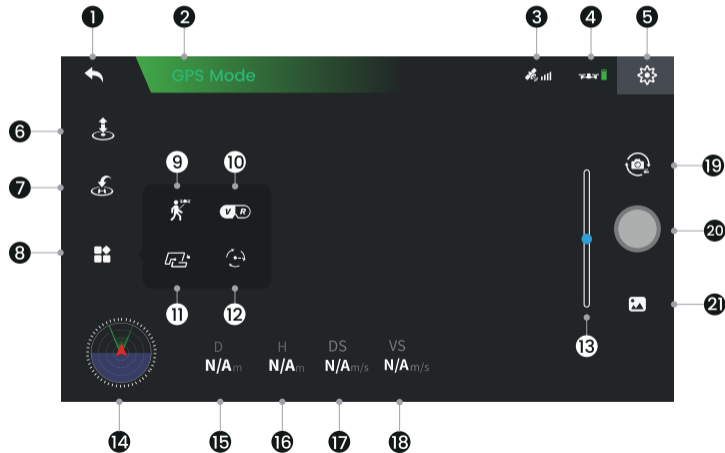









- 1 Homepage : Tap this icon to return to the main menu.
- 2 Status bar: Displays the current status of the drone.
- 3 GPS Signal : Displays the current GPS signal strength.
- 4 Drone Battery Level : Real-time display of the current battery level of the drone.
- 5 Flight Setting : Tap to enter the setting interface. Alter settings for flight height/distance, etc.
- 6 Takeoff/Landing : Tap this after unlocking to initiate a takeoff/landing.
- 7 Return to Home : Tap to bring the drone back to the Home Point.
- 8 Multi-functions : Tap to choose from multiple functions.

9 GPS Follow : Upon tapping, the GPS Follow function is activated. The drone's head will align with the direction of your smartphone's GPS and follow its movement. (To activate this function, the following conditions must be met: the drone must be in GPS mode, with a flight distance between 16 ft to 131 ft, and a flight altitude between 16 ft to 131 ft.)

3.3 APP Functions >>

App Interface

- 10 VR : Pair the mobile phone with a pair of VR glasses (not included) first. Then use this function to watch 3D live feed in real-time.
- 11 Waypoint : Make sure the drone is already at or above 49 ft in altitude. Upon tapping, the Waypoint function is activated. The drone will fly along the path specified by the pilot. (This function is only usable in GPS mode.)
- 12 Circle Mode : Make sure the drone is already at or above 49 ft in altitude. The drone will perform a circular flight, either clockwise or counterclockwise, around its current position, with its nose facing inward. (This function is only usable in GPS mode.)
- 13 Camera Angle Adjustment : The camera angle adjustment slider will appear on the right side of the screen. At this point, if you move the slider upward, the drone's camera will tilt upwards by a certain angle; if you move the slider downward, the drone's camera will tilt downwards by a certain angle.
- 14 Map : Tap the Mini Map to switch between Camera View and Map View.

- 15 Flight Distance $\frac{D}{N/A_m}$: Horizontal distance from the Home Point.
- 16 Flight Height $\frac{H}{N/A_m}$: Vertical distance from the Home Point.
- 17 Horizontal Speed $\frac{DS}{N/A_{m/s}}$: Drone's speed in the horizontal direction.
- 18 Vertical Speed $\frac{VS}{N/A_{m/s}}$: Drone's speed in the vertical direction.
- 19 Photo/Video : Tap to switch between photo taking and video recording.
- 20 Shutter/Record Button : Tap to take a photo or to start or stop recording a video.
- 21 Album : Tap to view photos and videos taken by the drone's camera.

3.3 APP Functions >>

Beginner Mode

It's recommended that beginner pilots first familiarize themselves with the drone by using beginner mode. In Beginner mode, which is the default operating mode, the following settings apply:



- 1 Flight Height is restricted to a range of 0–66 ft.
- 2 Flight Distance is capped between 0–66 ft.

To alter the settings mentioned above, you'll need to turn off beginner mode first.

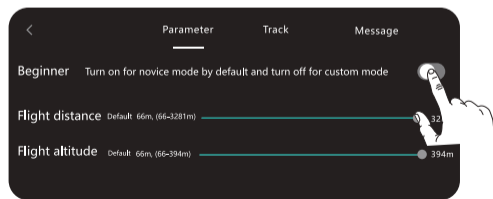
Flight Settings
On APP

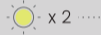

3.4 Drone Status Indicator >>

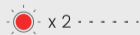
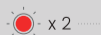
Indicator Status	Meanings
 [Red] Slow Flashing	Unsuccessful pairing after powering on the drone.
 [Yellow] Double Flashing	Paired successful/Searching for GPS signals.
 [Green] Steady	GPS signal search successful.
 [Yellow] Steady	Successfully exited GPS mode.
 [Red] Slow Double Flashing	Entered first stage of Low Voltage RTH.
 [Red] Fast Double Flashing	Entered second stage of Low Voltage RTH.

4.1 Specifications >>

• **DRONE:**

Model: HS175G	Weight: 249g/8.8oz
Max Flight Time: 30 minutes <i>(in a windless environment)</i>	Max Flight Height: 394 ft/120m
Max Wind Speed Resistance: 3.5m/s	Max Takeoff Altitude: 11483 ft/3500m
Operating Temperature Range: 32° to 104°F <i>(0° to 40°C)</i>	Max Flight Speed: 9 m/s
Size: 334*234*60 mm (unfolded)	152*80*60 mm (folded)

• **DRONE BATTERY:**

Model: 753075G	Capacity: 2100mAh
Voltage: 7.7V	Max Charging Voltage: 8.8V
Energy: 16.17Wh	Battery Type: Lithium-ion Polymer Battery
Charging Temperature Range: 41° to 104°F <i>(5° to 40°C)</i>	
Fastest charging time: approximately 1.5 hours (using Fast Chargers)	

4.1 Specifications >>

• **USB CHARGING CABLE:**

Input: 5V/2A	Rated Power: ≤10W
--------------	-------------------

• **TRANSMITTER:**

Operating Frequency: 2452-2474MHz	Max Flight Distance: 3281 ft/1000 m <i>(outdoor and unobstructed)</i>
Battery Type: 3.7V 1800mAh Lithium-ion Polymer battery	
Operating Temperature Range: 32° to 104°F <i>(0° to 40°C)</i>	Charging Time: 4 hours

• **CAMERA :**

Operating Frequency: 5500-5700MHz	Controllable Range: -90° to 0°
Photo Resolution: 3840*2160P <i>(when stored in TF card)</i>	3840*2160P <i>(when stored in cellphone)</i>
Video Resolution: 2560*1440P@30fps <i>(when stored in TF card)</i>	1280*720P@30fps <i>(when stored in cellphone)</i>
Max Transmission Distance: 2625ft/800m <i>(outdoor and unobstructed)</i>	Lens: FOV 120°
Photo Formats: JPEG	Video Formats: AVI/MP4
Supported TF Cards: Supports a TF Card (Class 10 or above) with capacity of up to 128 GB.	File Systems: FAT32

4.2 Contact Us >>

Please do not hesitate to contact us if you need further support.



eu@holystone.com (Europe)
usa@holystone.com (America)
ca@holystone.com (Canada)
au@holystone.com (Australia)



+1 (833) 766-4733



www.holystone.com

4.3 Troubleshooting >>

Issues	Possible Causes	Suggested Solutions
Motors won't start.	Weak GPS signal.	(1)Ensure you're operating in an area with strong GPS reception. (2)For indoor operations, short press the  button to exit GPS mode. (See page 22)
	The drone battery is low.	Recharge the battery.
	The compass isn't calibrated (Drone Status Indicators flash yellow).	Conduct a compass calibration. For step-by-step instructions, refer to the "Compass Calibration" section in the user manual. (See page 19)
Unstable flight or abnormal posture	GPS signal instability due to flying near buildings or in areas with obstructions.	Operate the drone in open spaces free from obstructions.
	Compass interference.	(1)Manually land the drone immediately and recalibrate the compass. (2)Try operating in a different location, ensuring you're away from buildings, power lines, and signal towers.
	Drone malfunction or after a collision.	Calibrate on a flat surface: push both sticks to the bottom right corner until drone lights become steady.
	Unstable air pressure or poor optical flow condition during flight.	Consider changing to a suitable flight environment. (See page 37)
Cannot execute waypoint function	Propeller deformation or damage.	Replace with new propellers. (See page 11)
	Map is not pre-loaded.	Load the map in the app ahead of time using mobile data or a WiFi network with internet access.
	Flying too low.	Only use this function at altitudes of 49ft or above.

4.4 Compliance Information >>

FCC Notice:

This device complies with part 15 of the FCC Rules. Operation is subject to the following two conditions:

- (1) This device may not cause harmful interference, and
- (2) This device must accept any interference received, including interference that may cause undesired operation.

The Supplier's Declaration of Conformity is available at the following address:

https://www.holystone.com/Download/US/HS175G_FCC_sDoC.pdf

This equipment has been tested and found to comply with the limits for a Class B digital device, pursuant to part 15 of the FCC Rules. These limits are designed to provide reasonable protection against harmful interference in a residential installation. This equipment generates, uses and can radiate radio frequency energy and, if not installed and used in accordance with the instructions, may cause harmful interference to radio communications. However, there is no guarantee that interference will not occur in a particular installation. If this equipment does cause harmful interference to radio or television reception, which can be determined by turning the equipment off and on, the user is encouraged to try to correct the interference by one or more of the following measures:

- Reorient or relocate the receiving antenna.
- Increase the separation between the equipment and receiver.
- Connect the equipment into an outlet on a circuit different from that to which the receiver is connected.
- Consult the dealer or an experienced radio/TV technician for help.

Changes or modifications not expressly approved by the party responsible for compliance could void the user's authority to operate the equipment.

4.4 Compliance Information >>

RF Exposure:

The equipment complies with FCC radiation exposure limits set forth for an uncontrolled environment. This device should be installed and operated with minimum distance 20cm between the radiator & your body.

IC Notice:

This device is restricted to indoor use when operating in the 5150 to 5250 MHz frequency range.

This device complies with Canada Industry licence-exempt RSS standard(s).

Operation is subject to the following two conditions:

- (1) this device may not cause interference; and
- (2) this device must accept any interference. Including interference that may cause undesired operation of the device.

CAN ICES-003 (B):

Avis d'Industrie Canada

Le présent appareil est conforme aux CNR d'industrie Canada applicables aux appareils radio exempts de licence. L'exploitation est autorisée aux deux conditions suivantes:

- (1) l'appareil ne doit pas produire de brouillage; et
- (2) l'utilisateur de l'appareil doit accepter brouillage radioélectrique subi même si le brouillage est susceptible d'en compromettre le fonctionnement. mauvais fonctionnement de l'appareil. Cet appareil numérique de la classe B est conforme à la norme NMB-003 du Canada.

4.4 Compliance Information >>

CAN NMB-003 (B):

RF Exposure

Radiation Exposure Statement:

This equipment complies with IC radiation exposure limits set forth for an uncontrolled environment. This equipment should be installed and operated with a minimum distance of 20cm between the radiator & your body.

Déclaration d'exposition aux radiations:

Cet équipement est conforme aux limites d'exposition aux rayonnements IC établies pour un environnement non contrôlé. Cet équipement doit être installé et utilisé avec un minimum de 20 cm de distance entre la source de rayonnement et votre corps.

EU RF Power(EIRP): <14 dBm (2452MHz-2474 MHz)

Caution

1. The max operating of the EUT is 40°C, and shouldn't be lower than 0°C.
2. The device complies with RF specifications when the device used at 0mm from your body.
3. Declaration of Conformity.

We, Xiamen Huoshiquan Import & Export CO.,LTD hereby, declare that the UAS HS175G is of class C0, and in compliance with the RED Directive 2014/53/EU, the RoHS Directive 2011/65/EU, Toy Directive 2009/48/EC and UAS Delegated Regulation 2019/945/EU amended by Delegated Regulation 2020/1058/EU.

4.4 Compliance Information >>

The full EU declaration of conformity is accessible at the following website:

http://www.holystone.com/Download/CE/HS175G_EU_DOC.pdf

This product can be used among EU member states.

MANUFACTURER INFORMATION:

Manufactured by

Xiamen Huoshiquan Import & Export CO.,LTD.

Address: Unit 1, Room 501, Hongxiang Building, No.258 Hubin Nan Road, Siming District, Xiamen, China

+1 (833) 766-4733

MTOM Statement:

HS175G is a quadrotor drone. The MTOM of HS175G is 249g, including the propellers, the Flight Battery, TF card, which is compliant with C0 requirements.

Users must follow the instructions below to comply with the MTOM C0 requirements. Otherwise, the drone cannot be used as a C0 aircraft:

1. DO NOT add any payload to the aircraft except the items listed in the List of Items including qualified accessories section.
2. DO NOT use any non-qualified replacement parts, such as flight batteries or propellers, etc.
3. DO NOT retrofit the aircraft.

List of Items including qualified accessories

1. HS175G Propellers (Model: HS175G-FY, 0.7 g each propeller, 10200RPM)
2. HS175G Flight Battery (approx. 85.5 g)
3. HS175G TF card (approx. 0.3 g)

4.4 Compliance Information >>

List of Spare and Replacement Parts

1. HS175G Propellers (0.7g each propeller)
2. HS175G Flight Battery (approx. 85.5 g)

List of Safe Guards

Below is the list of the mechanical safeguards and operation safeguards for HS175G.

1. Emergency Stop function can be performed to stop the motors in case of an emergency. Refer to the Emergency Stop section for details.
2. Prevent the drone from flying in restricted airspace. Refer to the Flight Environment Requirements section for details.
3. The Return to Home (RTH) function. Refer to the GPS Return to Home section for details.
4. The Optical Flow Positioning. Refer to the Optical Flow Positioning section for details.

Similar products produced by the same manufacturer are electrically identical. Distinguish them based on product model and appearance color.

The firmware of toy product cannot be upgraded. In the future, new versions of the app will be released through the app store. Users can update the app by scanning the QR code in the instruction or searching "HS GPS V5" on the app store.



MADE IN CHINA(CN)