

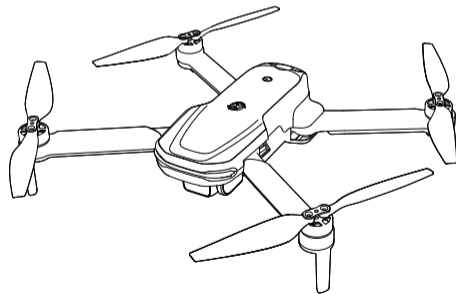

HS280D

User Manual
Gebrauchsanweisung
取扱説明書

V 1.0



+1 (833) 766-4733

www.holystone.com

usa@holystone.com (USA)

ca@holystone.com (CA)

eu@holystone.com (EU)

au@holystone.com (AU)

jp@holystone.com (JP)

English

01-41

Deutsch

42-80

日本語

81-120

CONTENTS

1

Product Profile

- 01 Package Contents
- 02 Diagram of the Drone
- 03 Diagram of the Transmitter

2

Drone Functions

- 19 Flight Functions
- 27 Attitude Adjustment
- 30 Stabilization Functions

3

Operation Guide

- 07 Battery Preparation
- 09 Pre-Flight Preparations
- 12 Pre-Flight Checklist
- 13 Flight

4

Appendix

- 33 Specifications
- 35 Contact Us
- 36 Troubleshooting
- 37 Compliance Information

Reading Guidance

Icon

“⚠️” essential precautions. “💡” tips for operation and usage.

Recommended Steps

Our product offers both tutorial videos and the following resources:

- Disclaimer and Safety Guidelines
- Quick Start Guide
- User Manual

For a smooth start, we suggest watching the tutorial videos and reviewing the "Disclaimer and Safety Guidelines" first. Then, familiarize yourself with the basics through the "Quick Start Guide". For a comprehensive understanding, delve into the "User Manual".

Access Tutorial Videos

To ensure you're using the product safely and correctly, scan the QR code below to view our tutorial videos.



Download the HS FPV V4 App

Simply scan the QR code below.



iOS



Android APP on Google play

💡 Required Operating Systems: iOS 12.0 or later / Android 5.0 or later.

1.1 Package Contents >>

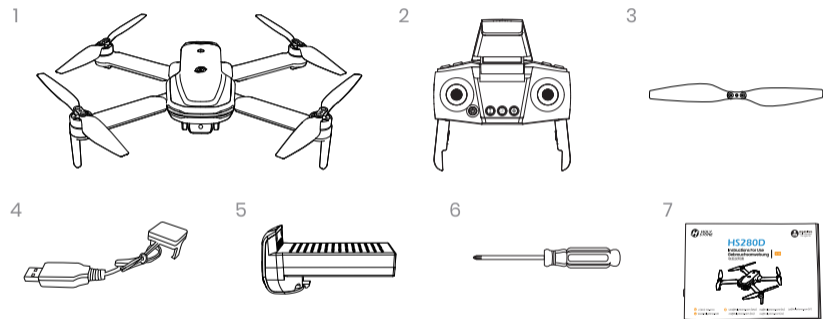

- 1 Drone
- 2 Transmitter
- 3 Propellers
- 4 USB Charging Cable
- 5 Drone Battery
- 6 Screwdriver
- 7 User Manual

1.2 Diagram of the Drone >>

Drone

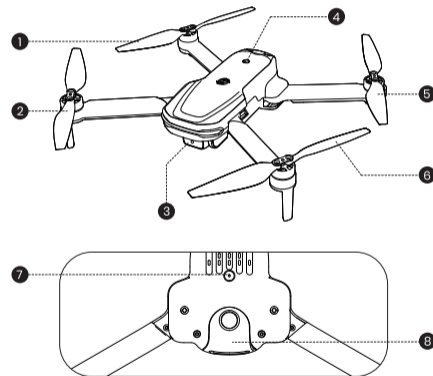

- 1 Propeller A
- 2 Propeller B
- 3 HD Camera
- 4 Power Switch: long press
- 5 Propeller B
- 6 Propeller A
- 7 Optical Flow Positioning Lens
- 8 Drone Battery

 Turning on/off: Long press the power switch on the drone to turn it on/off.

1.3 Diagram of the Transmitter >>

The Transmitter

● Front:

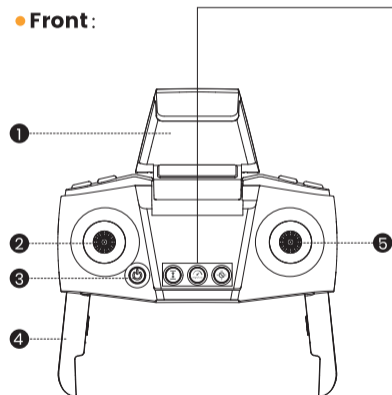

● Top:

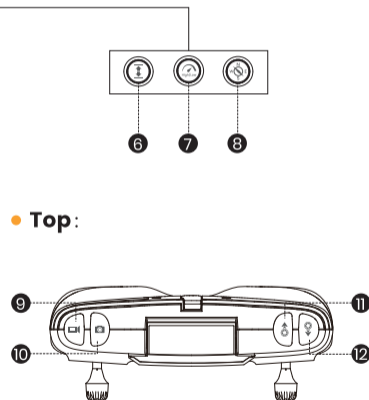

1 Phone Holder

2 Left Joystick | Trimmer: long press

3 Power Switch

4 Foldable Handle

5 Right Joystick

6 Unlock/Trimmer: short press

7 Speed Switch: short press

8 Headless Mode: short press

9 Record Video: short press

10 Take Photo: short press

11 Lens Up

12 Lens Down



- 💡 · Turning on/off: Short press the power switch on the transmitter to turn it on/off.
- Activate trimm mode: Push down and hold the left joystick.

1.3 Diagram of the Transmitter >>

Joystick Mode

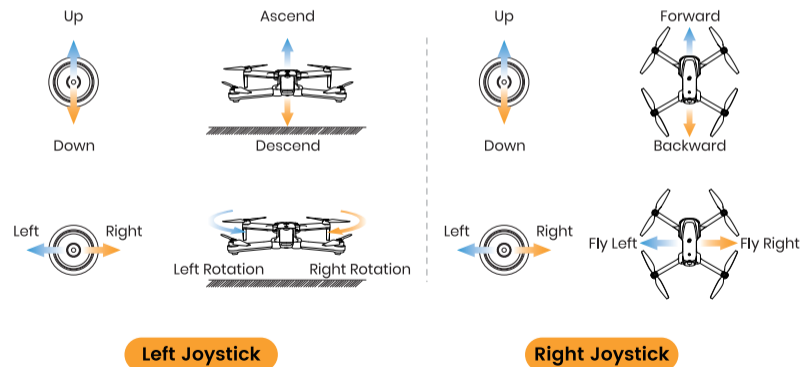
- **MODE 2 :** (The default setting, i.e., left joystick as the throttle joystick.)



- **MODE 1 :** To enter MODE 1, turn on the transmitter while holding the  button. (Please do not release the  button until the transmitter is powered on.)

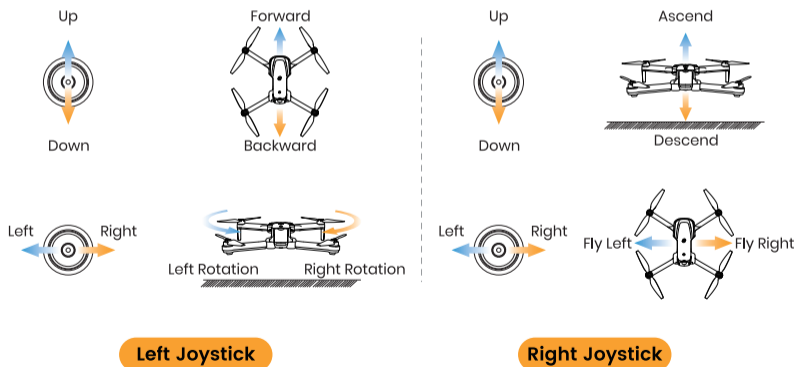

2.1 Battery Preparation >>

Drone Battery

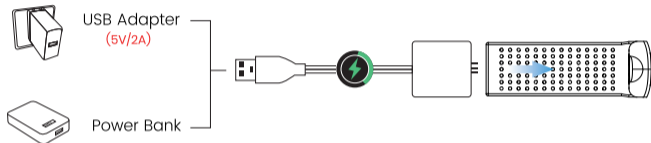

- 1 Remove the battery from the drone and connect it to a USB charging cable.
- 2 Plug the USB charging cable into a USB charging port on a power bank or a USB adapter (5V/2A).
- 3 The red light on the USB charging cable illuminates during charging and goes off once the battery is fully charged.
- 4 Charging time: About **70 minutes**.

***Low Battery Signal:** Indicator lights on the drone keep flashing.

- ⚠ Before charging, please read the instructions in the "Battery Safety" section of the "Disclaimer and Safety Guidelines" carefully!
- DO NOT charge a battery immediately after a flight as the temperature may be too high. Please wait until it cools down to room temperature before charging again.
- Please use the original charging cable to charge the battery.

2.1 Battery Preparation >>

Changing Transmitter Batteries

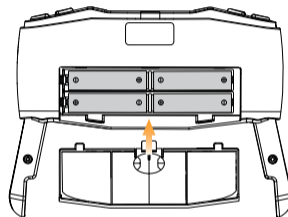

Remove the battery cover on the back of the transmitter. Put in four AAA batteries (not included). Then, put the cover back on.

***Low Battery Signal:** The power indicator on the transmitter will flash red and the transmitter will beep continuously.

- 💡 Install batteries carefully.
- Do not mix old and new batteries.
- Do not mix different types of batteries.

2.2 Pre-Flight Preparations >>

Propellers

● Installation:

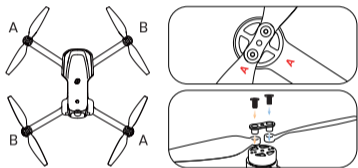

The drone will not fly unless the correct propeller is installed on the correct motor shaft. Each propeller is labeled with either an "A" or "B." Secure the propeller onto the motor shaft using screws, turning each screw clockwise.

● Removal:

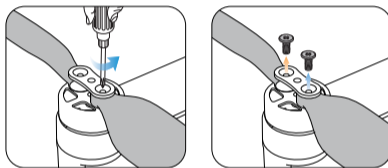

For propeller removal, use a screwdriver (provided) to rotate the screws counter-clockwise and remove the propellers. Be sure to hold the motor while detaching the propeller.



- Please check that the propellers are properly installed and tightened before each flight.
- Exercise caution when attaching/detaching the propellers to prevent any cuts or injuries.
- The propellers are installed before the drone is packaged at the factory.

2.2 Pre-Flight Preparations >>

Drone Battery

● Installation:

* Before installing the battery, please check if it has a detachable insulation pad/band. If yes, remove it.

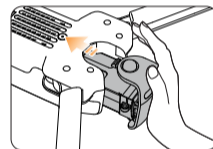

Push the battery correctly into the drone. Make sure that you hear a click sound, which indicates that the battery is firmly installed.



- The battery should be installed firmly. Otherwise, the flight safety of your drone may be affected. The drone may crash due to a power-cut during the flight.

● Removal:

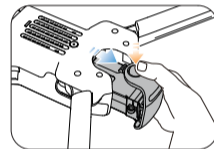

Press the lock button on the battery, and pull the battery out from the drone.

2.2 Pre-Flight Preparations >>

Foldable Handles

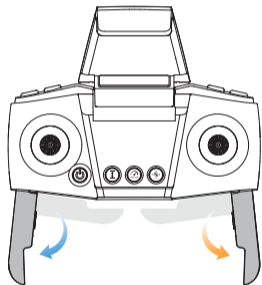

Expand the foldable handles on the transmitter separately.

Phone Holder

- Expandable Phone Holder

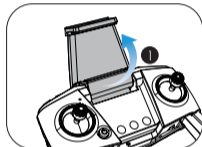

- Adjustable Clamp

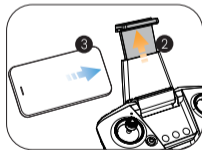

Expand the phone holder and place your mobile phone in it. Adjust the clamp to secure your mobile phone.

2.3 Pre-Flight Checklist >>

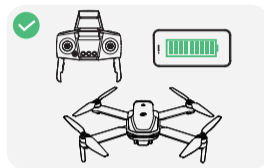

Make sure the transmitter, the mobile phone and the drone battery are fully charged.

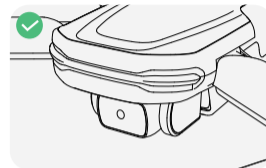

Make sure that the camera is clean.

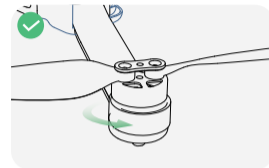

Make sure that there is nothing obstructing the motors.



Make sure the drone arms are unfolded.

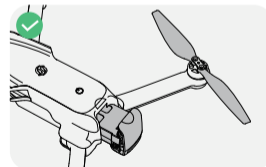

Make sure the drone battery and the propellers are mounted securely.



Make sure you use accessories provided by this company.

2.4 Flight >>

Pairing

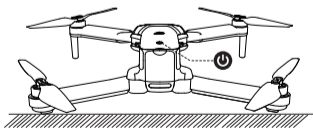

- All of the operations shown in this manual are demonstrated using MODE 2.
- You must keep your drone in visual line of sight all the time. If you can't see it, you can't control it.

**1 Turning on the drone**

Place it on a level surface with its head pointing forward. Long press the power switch to turn on the drone. The indicator lights on the drone begin to flash.

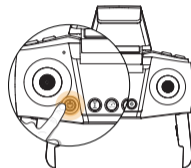
**2 Turning on the transmitter**

Short press the power switch on the transmitter to turn it on; its indicator light will start to flash.

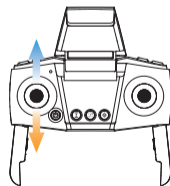
**3 Pairing**

Move the left joystick up and then back down to pair the drone with the transmitter. Successful pairing is confirmed when the indicator lights on both the drone and the transmitter become steady and the transmitter produces a prolonged beep.

2.4 Flight >>

Wi-Fi Connection

 Make sure the pairing has finished before going to the Wi-Fi settings on your phone.

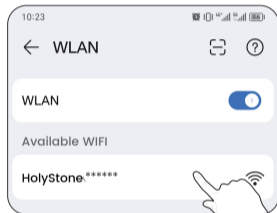

- 1 Go to the **Wi-Fi** settings on your phone.
- 2 Connect to the drone's Wi-Fi network: **HolyStone-*******.
- 3 Run the HS FPV V4 app. A successful connection is confirmed **when the drone's live video feed is displayed within the app interface**.



- Connecting your phone to the drone's Wi-Fi may take some time. Please remain patient and wait for the connection to be established successfully.
- For optimal connectivity, if you're experiencing issues with the WiFi connection or the image transmission in the APP isn't displaying, it's advised to disable your phone's Bluetooth, Mobile Data, and VPN. Alternatively, switch your phone to airplane mode and attempt to reconnect.
- Please ensure that **all** permissions requested by the app are granted.



The Wi-Fi network created by the drone does not have internet access. As a result, your cellphone might:

- Notify you that the connection isn't secure,
 - Indicate there's no internet connection, or
 - Suggest switching to cellular data.
- (The exact wording may vary based on cellphone models.)

Please disregard these messages. If prompted, select the option to remain connected to the current Wi-Fi.

2.4 Flight >>

Unlocking the Motors

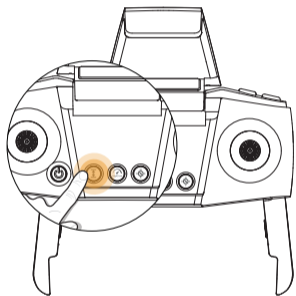

Short press the  button. The motors will rotate, and the drone is unlocked.



 To lock the motors: Push both joysticks to the lower inner corners.

2.4 Flight >>

Takeoff/Landing

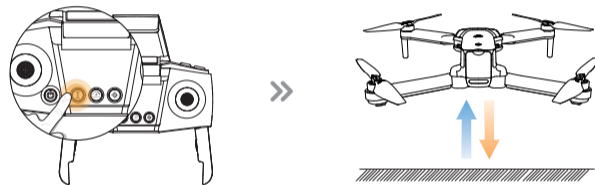
 Remember to unlock the motors before takeoff.



 **Takeoff** Short press the  button, the drone will take off automatically and hover at **5 ft**. Now you can control the drone by using the joysticks.

 **Landing** During the flight, short press the  button, the drone will land on the ground automatically.

3.1 Flight Functions >>

Camera Angle Adjustment

You can adjust the camera to tilt **up or down** with the  and  buttons. (The camera has a control tilt range of -70° ~ 0° .)

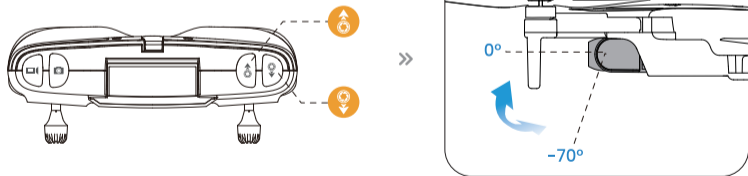

3.1 Flight Functions >>

Take Photo/Record Video

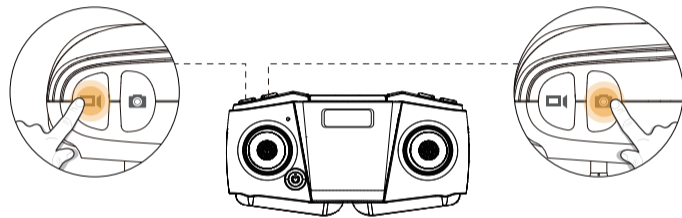

Record Video: Short press the  button on the transmitter. The transmitter will beep twice, indicating that video recording has started. A brief press again stops the recording, and the transmitter emits a prolonged beep.

Take Photo: Short press the  button on the transmitter to take a photo. The transmitter will beep once, signaling that a photo has been taken.



You can't take photos while recording videos.

3.1 Flight Functions >>

Speed Switch

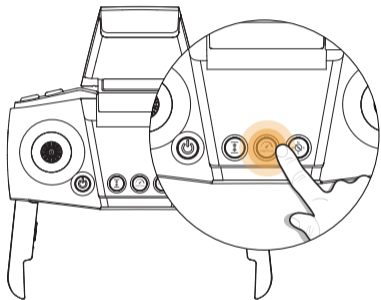

This drone offers two speed modes: **Low and High**. By default, it's set to Low speed.

To toggle between the modes, give the  button a short press. A single beep signifies Low speed, while a double beep denotes High speed.

3.1 Flight Functions >>

Headless Mode

The Headless Mode is a great training tool for beginner pilots. It is also useful when the drone is too far from the pilot (**which makes it difficult to tell its orientation**). It keeps the drone traveling forward, backward, left, or right when you move the right joystick in those directions, regardless of which way the front of the drone is pointed.

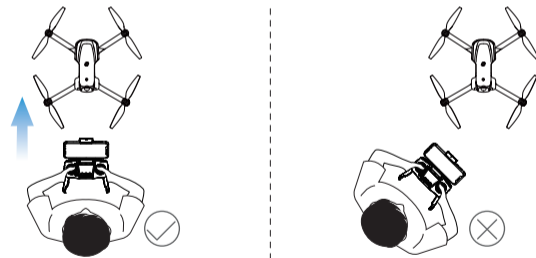



The pilot should stay facing the same direction that the drone's head points to when it takes off.

3.1 Flight Functions >>

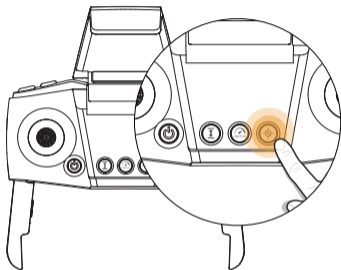
Headless Mode



- 1 **ACTIVATING:** Short press the  button to activate this mode. While in Headless Mode, the indicator light will flash continuously, and the transmitter will beep continuously.
- 2 **DEACTIVATING:** Press the  button once more. A prolonged beep will sound, and the indicator light will return to a steady glow, indicating the drone has successfully exited Headless Mode.



* Why is the orientation of the drone important?

In normal flying mode, the control of the drone movement can sometimes be counter-intuitive for beginners. For instance, when the drone is in the air with its head pointing to your right, if you push the right joystick forward, the drone will fly to your right, instead of flying forward.

With the headless mode, the drone has a fixed "head." In Headless Mode, the drone always remembers the side its head points to during takeoff as the front side. This means that if the drone takes off with its head pointing forward, it doesn't matter how the drone is oriented in the air, when you push the right joystick forward, the drone will fly forward. Or, when its head is pointing to you, if you push the right joystick to the left, the drone will fly to your left.

3.1 Flight Functions >>

Emergency Stop

- 1 The Emergency Stop function should only be used in an emergency during the flight to avoid any damage or injury. **Long Press the  button and the  button simultaneously.** The transmitter will beep continuously. The drone will descend quickly to the ground.

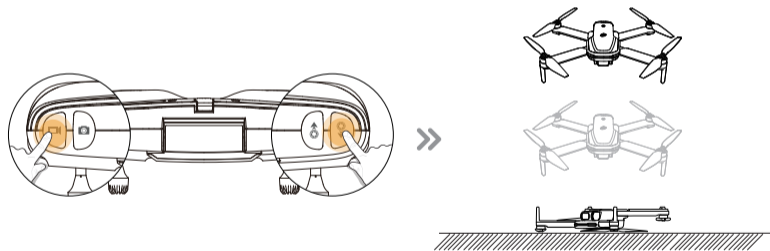

-  Be aware that you risk breakage of the drone if it falls from a large distance or hits anything at a high rate of speed.

- 2 After the drone hits the ground, The rear indicator light on the drone will keep on flashing. **Please put the drone on a level surface** again, and push the left joystick downward. The indicator lights then turn from flashing to solid, which indicates that you can use the drone now.

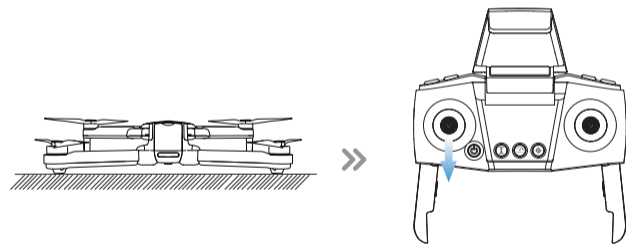

3.2 Attitude Adjustment >>

Trimming

 **Trim adjustments are designed to counter drifts not caused by airflow.**

1 Initiate Trim Mode: Press down and hold the **left joystick** throughout the trimming process.

2 L/R Sideward Trim:

- If the drone drifts to the left, push the right joystick to the right.
- If the drone drifts to the right, push the right joystick to the left.

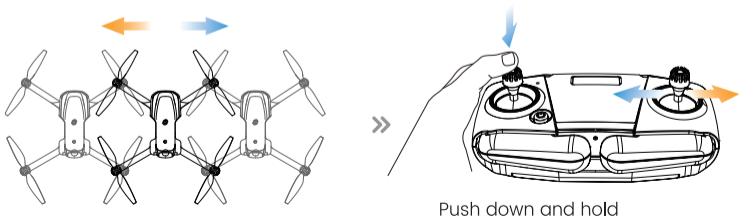

3 F/B Sideward Trim:

- If the drone drifts forward, push the right joystick downward.
- If the drone drifts backward, push the right joystick upward.

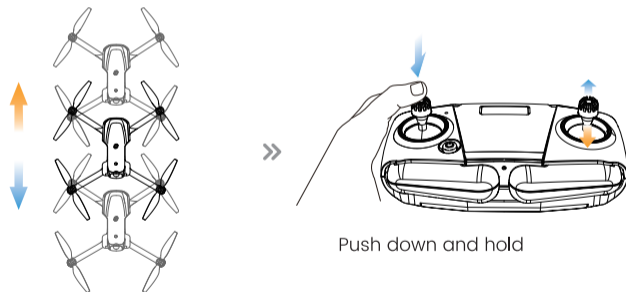

4 Deactivate Trim Mode: Once adjustments are made, release the left joystick to exit trim mode.

3.2 Attitude Adjustment >>

Gyro-Calibration

-  Please perform gyro-calibration in the following scenarios:
1. After a collision or fall.
 2. When the drone exhibits abnormal behavior.

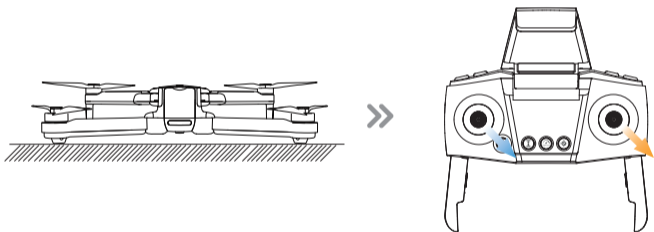

Make sure to place the drone on a level surface before calibrating the gyro. Simultaneously push the left joystick and the right joystick to the bottom right corner to calibrate the gyro. The indicator lights on the drone will blink, then turn solid, which indicates that the calibration is completed.

3.3 Stabilization Functions >>

Altitude-Hold Function

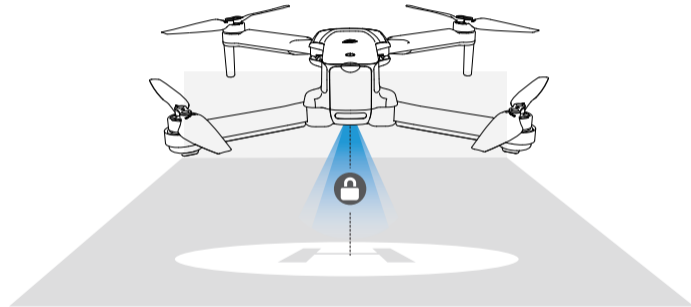

The drone is designed with an **altitude-hold** function to maintain its altitude after releasing the left joystick. (The left joystick will automatically spring back to the middle)

3.3 Stabilization Functions >>

Optical Flow Positioning

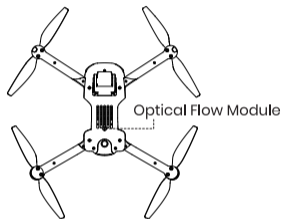

The Optical Flow Positioning System consists of a camera module, which acquires the position information of the drone through visual images to ensure precise positioning of the drone. The optimal usage height for Optical Flow Mode is 1.6–9.8ft.



- The precision of the Optical Flow Positioning System is easily affected by the light intensity and features of the surface textures. Once the image sensor is not available, your drone will switch on the altitude-hold function automatically. Please exercise utmost caution when operating the drone under these circumstances:

- Fly over surfaces without clear patterns or textures.
 - Fly over extremely dark or bright surfaces.
 - Fly in an area where the lighting changes dramatically and frequently.
 - Fly over moving surfaces or objects. (e.g., above crowds, above bushes or grasses swayed by strong winds).
 - Fly over water or transparent surfaces.
 - Fly over highly light reflective surfaces. (e.g., mirrors).
 - Fly over monochrome surfaces (e.g., pure black, red, or green).
 - Flying over surfaces with repeating identical patterns or textures (e.g., tiles with the same design).
 - Flying speed should be controlled not to be too fast.
- Keep sensors clean at all times.
 - DO NOT scratch or tamper with the sensors. DO NOT use the aircraft in dusty or humid environments.
 - Make sure that the light is bright enough and the surface is with clear textures so that the Optical Flow Positioning can acquire the movement information through recognizing the ground textures.

4.1 Specifications >>

• DRONE:

Model: HS280D	Weight: 164g/5.8oz
Max Flight Time: 14 minutes <small>(in a windless environment)</small>	Max Flight Height: 131ft/40m
Operating Temperature Range: 32° to 104°F (0° to 40°C)	
Size : 335*210*52 mm (unfolded)	135*80*52 mm (folded)

• DRONE BATTERY:

Capacity: 1300mAh	Voltage: 3.85V
Battery Type: Lithium-ion Polymer Battery	Energy: 5.01Wh
Charging Temperature Range: 41° to 104°F (5° to 40°C)	
Charging Time: About 70 minutes	

• USB CHARGING CABLE:

Input: 5V/2A	Rated Power: ≤10W
--------------	-------------------

• TRANSMITTER:

Operating Frequency: 2452-2474MHz	Max Flight Distance: 328 ft/100 m <small>(outdoor and unobstructed)</small>
Battery Type: 4 × AAA Battery (not included)	
Operating Temperature Range: 32° to 104°F (0° to 40°C)	

• CAMERA:

Operating Frequency: 2417MHz	Photo Resolution: 1920×1080P
Video Resolution: 1920×1080P@25fps	Max Transmission Distance: 328ft/100m <small>(outdoor and unobstructed)</small>
Lens: FOV 65°	Controllable Range: -70° to 0°
Photo Formats: JPEG	Video Formats: MP4

4.2 Contact Us >>

Please do not hesitate to contact us if you need further support.



usa@holystone.com (America)
 eu@holystone.com (Europe)
 jp@holystone.com (Japan)
 ca@holystone.com (Canada)
 au@holystone.com (Australia)



+1 (833) 766-4733

4.3 Troubleshooting >>

Issue	Possible Causes	Suggested Solutions
Motors won't start.	Pairing failed.	The drone defaults to Mode 2 upon startup. Please push the left joystick up and then down; the lights will stay on once pairing is successful.
	Insufficient Drone Battery Power (Flashing white light on the drone head and flashing green battery indicator light on the drone tail.)	Please charge the battery.
	Motor damage.	Replace with a new motor.
Instable hovering.	Unstable atmospheric pressure or poor optical flow conditions during flight.	If drifting occurs during flight, use the trim function to counter the drift (See page 27); change to a more suitable flying environment.
	Drone anomalies or collisions.	Perform horizontal calibration; on a level surface, simultaneously push the left and right joysticks to the 5 o'clock position and hold for 2 seconds, the lights will flash and then stay on once calibration is successful.
	Propeller deformation or damage.	Replace with new propellers (See page 9).
Image freezes. Shortened image transmission range.	Video transmission signal interference.	Operate the drone in open areas free from buildings, high voltage lines, and signal towers.
	Transmitter and smartphone not aligned with the drone's direction.	Keep the transmitter and smartphone aligned with the flight direction of the drone to ensure optimal signal radiation direction.
	Joystick moved too quickly when controlling the drone.	Move the joysticks slowly and at a steady pace.
	Smartphone lag.	Close idle apps running in the background to maintain optimal smartphone performance.

4.4 Compliance Information >>

FCC Notice:

This device complies with part 15 of the FCC Rules. Operation is subject to the following two conditions:

- (1) This device may not cause harmful interference, and
- (2) This device must accept any interference received, including interference that may cause undesired operation.

The Supplier's Declaration of Conformity is available at the following address:

https://www.holystone.com/Download/US/HS280D_FCC_sDoC.pdf

This equipment has been tested and found to comply with the limits for a Class B digital device, pursuant to part 15 of the FCC Rules. These limits are designed to provide reasonable protection against harmful interference in a residential installation. This equipment generates, uses and can radiate radio frequency energy and, if not installed and used in accordance with the instructions, may cause harmful interference to radio communications. However, there is no guarantee that interference will not occur in a particular installation. If this equipment does cause harmful interference to radio or television reception, which can be determined by turning the equipment off and on, the user is encouraged to try to correct the interference by one or more of the following measures:

- Reorient or relocate the receiving antenna.
- Increase the separation between the equipment and receiver.
- Connect the equipment into an outlet on a circuit different from that to which the receiver is connected.
- Consult the dealer or an experienced radio/TV technician for help.

Changes or modifications not expressly approved by the party responsible for compliance could void the user's authority to operate the equipment.

4.4 Compliance Information >>

RF Exposure:

The equipment complies with FCC radiation exposure limits set forth for an uncontrolled environment. This device should be installed and operated with minimum distance 20cm between the radiator & your body.

IC Notice:

This device complies with Canada Industry licence-exempt RSS standard(s).

Operation is subject to the following two conditions:

- (1) this device may not cause interference; and
- (2) this device must accept any interference. Including interference that may cause undesired operation of the device.

CAN ICES-003 (B):

Avis d' Industrie Canada

Le présent appareil est conforme aux CNR d'industrie Canada applicables aux appareils radio exempts de licence L'exploitation est autorisée aux deux conditions suivantes:

- (1) l'appareil ne doit pas produire de brouillage; et
- (2) l'utilisateur de l'appareil doit accepter brouillage radioélectrique subi même si le brouillage est susceptible d'en compromettre le fonctionnement. mauvais fonctionnement de l'appareil. Cet appareil numérique de la classe B est conforme à la norme NMB-003 du Canada.

4.4 Compliance Information >>

CAN NMB-003 (B):

RF Exposure

Radiation Exposure Statement:

This equipment complies with IC radiation exposure limits set forth for an uncontrolled environment. This equipment should be installed and operated with a minimum distance of 20cm between the radiator & your body.

Déclaration d'exposition aux radiations:

Cet équipement est conforme aux limites d'exposition aux rayonnements IC établies pour un environnement non contrôlé. Cet équipement doit être installé et utilisé avec un minimum de 20 cm de distance entre la source de rayonnement et votre corps.

EU RF Power(EIRP): <10 dBm (2452MHz-2474 MHz)

CAN NMB-003 (B):

1. The max operating of the EUT is 45°C, and shouldn't be lower than -10°C.
2. The device complies with RF specifications when the device used at 0mm from your body.
3. Declaration of Conformity.

We, Xiamen Huoshiquan Import & Export CO.,LTD hereby, declare that the compliance of the essential requirements with the Directive 2014/53/EU, the RoHS Directive 2011/65/EU and Safety Directive 2009/48/EC have been fully fulfilled on our product with

4.4 Compliance Information >>

indication below:

Product Name: Remote control four axis series

Model/Mark:HS280D/HolyStone

The Statement of compliance is available at the following address:

http://www.holystone.com/Download/CE/HS280D_EU_DOC.pdf

This product can be used among EU member states.

MANUFACTURER INFORMATION:

Manufactured by

Xiamen Huoshiquan Import & Export CO.,LTD.

Address: Unit 1, Room 501, Hongxiang Building, No.258 Hubin Nan Road, Siming District, Xiamen, China
+1 (833) 766-4733

MTOM Statement

HS280D is a quadrotor drone. The MTOM of HS280D is 164g, including the propellers, the Flight Battery, which is compliant with C0 requirements.

Users must follow the instructions below to comply with the MTOM C0 requirements. Otherwise, the drone cannot be used as a C0 aircraft:

1. DO NOT add any payload to the aircraft except the items listed in the List of Items including qualified accessories section.
2. DO NOT use any non-qualified replacement parts, such as flight batteries or propellers, etc.
3. DO NOT retrofit the aircraft.

4.4 Compliance Information >>

List of Items including qualified accessories

1. HS280D Propellers (1.5 g each propeller)
2. HS280D Flight Battery (approx. 38 g)

List of Spare and Replacement Parts

1. HS280D Propellers (1.5 g each propeller)
2. HS280D Flight Battery (approx. 38 g)

List of Safe Guards

Below is the list of the mechanical safeguards and operation safeguards for HS280D.

1. Emergency Stop function can be performed to stop the motors in case of an emergency. Refer to the Emergency Stop section for details.
2. The Optical Flow Positioning. Refer to the Optical Flow Positioning section for details.
3. Prevent the drone from flying in restricted airspace. Refer to the Flight Environment Requirements section for details.



MADE IN CHINA(CN)